

# **Finite Element Simulation of 180° Rollover for Heavy Truck Vehicles**

T. Kim Parnell, M. ASCE Christopher V. White, M. ASCE and Shari E. Day, M. ASCE

*Exponent Failure Analysis Associates 149 Commonwealth Drive Menlo Park, CA 94025*  
*[Parnell@exponent.com](mailto:Parnell@exponent.com), [cwhite@exponent.com](mailto:cwhite@exponent.com), [sday@exponent.com](mailto:sday@exponent.com)*

## **Abstract**

The computer program LS-DYNA3D was used to simulate the behavior of a specific, though representative, heavy truck cab-over tractor-trailer vehicle during a full 180° rollover event. These simulations provide a key component in the development of a physical testing procedure for evaluating structural integrity and occupant crash protection system designs in heavy trucks.

## **Introduction**

Vehicle crashworthiness for passenger automobiles has been the focus of numerous research studies in recent years ((Hallquist, 1989), (Schwer, 1996)), but comparatively little attention has been paid to the crashworthiness of heavy trucks. The United States government, vehicle manufacturers, safety researchers, and private groups have all agreed on the need to better understand and improve heavy truck crashworthiness. Based on these concerns, the Society of Automotive Engineers (SAE) initiated a three-phase research program to evaluate various crashworthiness issues for heavy trucks. Phase I of the SAE Heavy Truck Crashworthiness program entails development of characteristic crash pulses and analysis of truck occupant dynamics (Cheng, et al., 1996a, 1996b, 1996c). Phase II of the program entails both computational and experimental tasks for the investigation of 180° rollovers, and is the subject of this paper. The Phase III work establishes recommended practices for evaluating truck crashworthiness designs.

The 180° dynamic rollover analyses that form Phase II of the SAE study provide critical information on the magnitude, direction and spatial distribution of ground contact forces during a rollover. The contact force vectors can be used to plan efficient full-scale static tests that more faithfully reproduce actual rollover forces on the cab structure. The analysis also provides a means for comparing different cab structural parameters, although this is not addressed in this paper.

Whereas typical barrier or vehicle-to-vehicle impacts have a duration of approximately 0.1 seconds, rollover events are typically one to three seconds, or more, in length. Such long duration events, which necessarily involve large deformation structural response, inelastic material behavior and element failure, present a significant computational challenge. Since the initial phase of the rollover event is essentially rigid, a kinematic (rigid-body) vehicle analysis can be used up to the instant the cab contacts with the ground. The deformable phase begins at the instant of cab-to-ground contact, and in this study, is carried forward for 1.25 seconds, using a deformable (finite element) model.

The remainder of this paper explains how the rigid body and the finite element analyses were developed then coupled together to form the complete rollover analysis. Key results from the rollover simulation are also presented.

### **Finite Element Model**

The computer program ANSYS was used to create the finite element model of the cab. The commercial computer program LS-DYNA3D / LS-TAURUS (Hallquist, 1994) was selected for the FE analysis because of its capabilities in handling contact, material degradation and tearing, weld failure, rigid body/flexible body coupling, and because the user has good control of time step size through mass scaling. Model size and mesh density were carefully optimized in order to avoid computation times of several days to more than a week on workstation-class computers. Because LS-DYNA3D uses an explicit solution method, mesh density was particularly critical for the few small or stiff elements that determine critical time step size.

An actual cab-over heavy truck cab design was used to construct the finite element model. In addition to detailed engineering drawings, three exemplar specimens of the cab structure were obtained; two were used for full-scale testing (described later in the paper), the third served as a modeling reference. Altogether, more than 60 component parts were included in the cab model alone. Close attention was paid to the front panel and door areas, and also to the connection details, as they have a profound influence on the load path, especially for nonlinear analyses. The final cab model, shown in Fig. 1, consists of 45 combinations of material types and shell thicknesses, 15 different beam sections, 8000 elements, and 9800 nodes.

The complete finite element model for the rollover simulation includes the flexible cab, a rigid chassis, and a rigid trailer. The geometry of the rigid bodies was defined with a finite element mesh, then assigned rigid material properties, then explicitly assigned inertial properties (CG location, mass and rotational inertias). Nodal constraints were used to join the cab to the chassis at four support points, and a ball-and-socket joint connects the chassis and trailer at the fifthwheel. A nonlinear rotational spring was lumped at the fifthwheel to provide resistance against relative torsion (about the longitudinal axis), and to approximate the windup energy stored in the torsionally flexible trailer.

### **Model Correlation**

Two full-scale quasi-static roof crush tests were performed on the exemplar cab structures at Exponent's Test and Engineering Center in Phoenix. Each test consisted of mounting the cab in a static test fixture and crushing the cab with a rigid steel platen. The cabs were instrumented to record reaction forces, deformations, and strains, and the tests were thoroughly documented by still photos and video from various angles. Platen force vs. time curves and video footage of the crush tests were used to identify critical structural behavior, which was then used to guide model development and subsequent correlation.

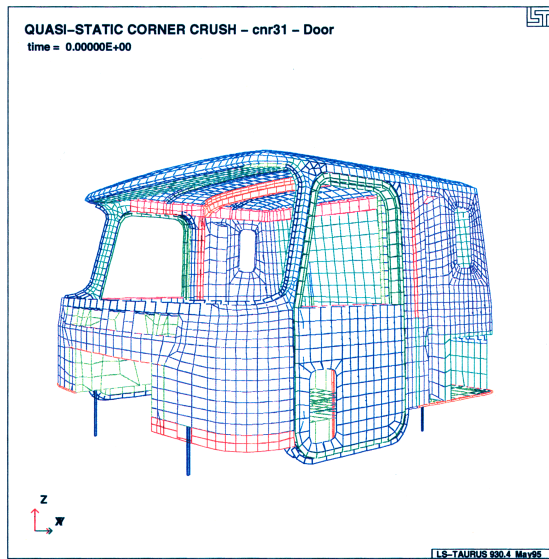

Figure 1 Finite Element mesh of cab.

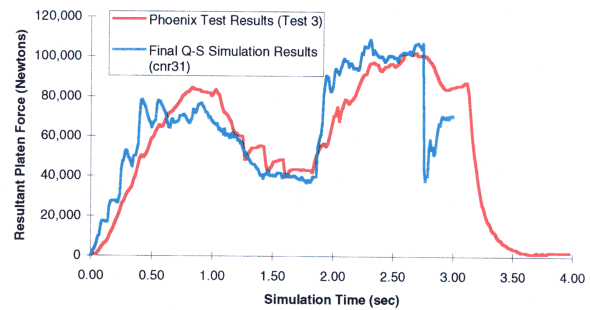

Figure 2 Platen force resultant vs. time.

A series of quasi-static finite element simulations replicating the physical tests was performed in LS-DYNA3D. Only the cab portion of the model was used for these simulations. Each simulation required between 9 and 14 hours of dedicated CPU time on an SGI Indigo2 with an R4400–200 MHz processor. More than 25 corner crush and 35 top crush runs were made, each exploring new model features or analysis options. Final agreement between simulation and test results is quite good, as shown in Figure 2. The initial stiffness and first peak of the platen load curve is relatively sensitive to A-pillar strength and stiffness and the contribution of the door frame. The second peak occurs due to the platen impinging on the cowl bar area at the base of the windshield.

### Rollover Analysis

To provide realistic conditions, the rollover analysis was based on a National Transportation Safety Board report of an actual highway accident involving a heavy truck 180° rollover (NTSB, 1988). The accident occurred while the vehicle was traveling in the left median strip at approximately 55 mph then swerved quickly to the right attempting to get back onto the pavement. The ensuing rollover was a trip about the left front driver's side of the vehicle.

A kinematic rigid body analysis was performed by a separate group of analysts using the computer program DADS. The kinematic analysis provides a complete state vector that fully characterizes the current condition (orientation, position, velocity, etc.) of each component of the vehicle. With appropriate post-processing, results from any time instant can be used as initial conditions for the finite element model. To minimize the length of the finite element analysis (which requires small time steps even when the

model is moving through rigid body motions and not deforming) the optimal starting point was determined to be 7.3 seconds into the accident, the instant immediately prior to impact of the cab on the ground.

Whereas the rigid body model is constructed of lumped masses and discrete springs, and can be defined by the position, the translational and rotational velocity of each body's CG, and its angular orientation, the finite element model is defined by thousands of nodes, each of which needs to be located in space and assigned the correct translational velocities. Projection of the rigid body positions computed with DADS onto the finite element nodes of the LS-DYNA3D model is accomplished with a custom MATLAB script file. MATLAB was chosen in favor of C or FORTRAN because of the ease in handling vectors and matrices, and because the calculations can be readily verified using MATLAB's built-in graphics and visualization features.

The default time step for the deformable phase of the rollover was computed automatically by LS-DYNA3D during a preliminary run. Using this default step size of approximately  $10^{-6}$  s (1 microsecond), a one-second rollover event was estimated to require approximately 9.5 days of CPU time. Examination of the model showed that six very short beam elements located near the lower part of the driver's-side door frame were controlling the time step. The mass scaling option of LS-DYNA3D allowed the use of artificially heavy material densities for those elements, with no appreciable change in total mass. This increased the speed of execution for a 1.25-second simulation to approximately 60 hours. The deformed cab at time  $t=0.86$  sec into the rollover is shown in Fig. 3.

The direction of the overall ground-to-cab contact force is depicted in Fig. 4. These plots show the projection of the resultant force onto each of the three orthogonal planes defined by the local coordinate system of the chassis. The numbers give the resultant of the two components in that plane. It is evident from the middle and bottom rows of the figure how the contact force begins from the driver's side and propagates around to the passenger side as the roll progresses.

## **Conclusion**

This research has shown that, despite the relatively long time span of the event, it is possible to apply the techniques of vehicle crashworthiness simulations to heavy truck rollovers. Photo and video documentation of the tests provided a valuable supplement to the quantitative results for the purposes of constructing and correlating the finite element model. Both rigid and deformable truck components were included in the dynamic rollover simulation. A substantial amount of customized programming was needed to apply initial conditions calculated with an all-rigid-body analysis in DADS to a rigid-body/finite element analysis in LS-DYNA3D. Custom programming was needed to post-process ground-to-cab contact forces so that they are aligned in the cab's local coordinate system.

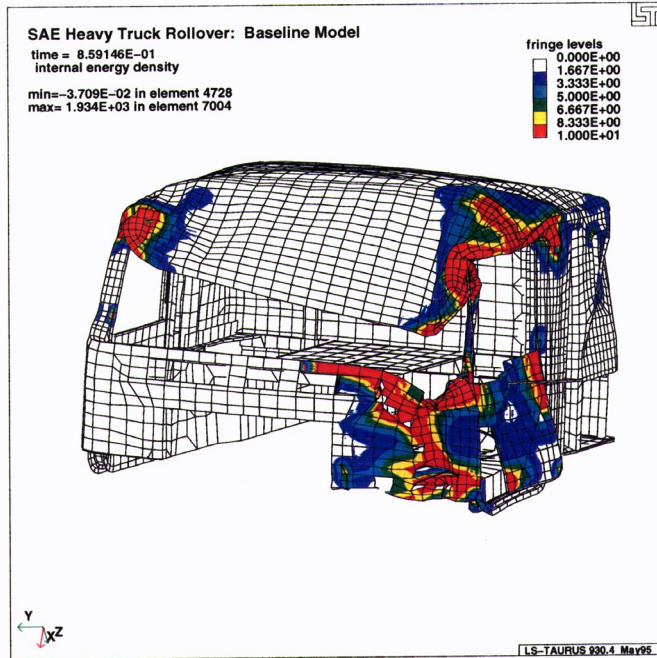

Figure 3 Deformed mesh at 0.86s showing strain energy distributions, localized element failures, and failures of seam welds.

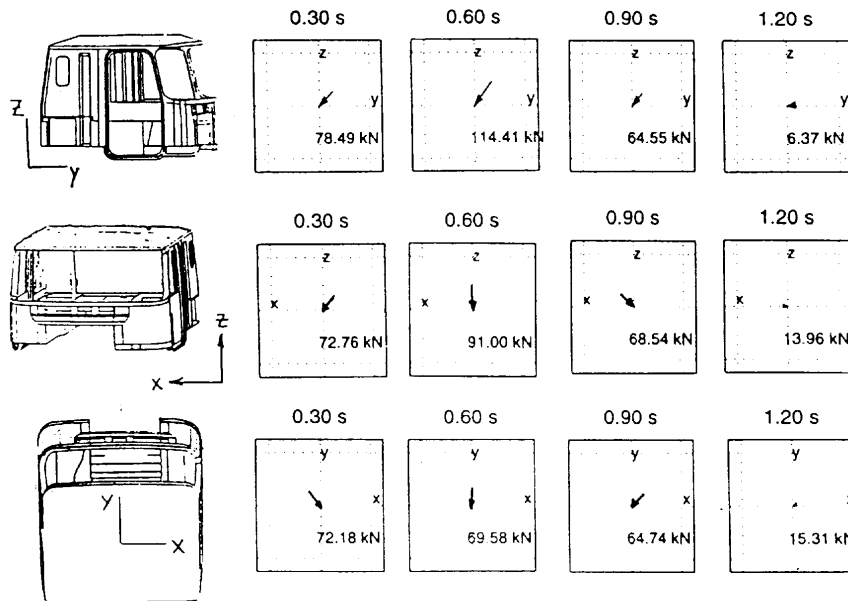

Figure 4 Each row shows the projection of overall ground-to-cab contact force onto one of the cab local coordinate system planes. The magnitudes are the vector resultant of components lying in that plane.

## **Acknowledgments**

The authors would like to thank the SAE Heavy Truck Crashworthiness Task Force for their active participation in this work. Members of the TACOM staff are acknowledged for providing the authors with the DADS rigid-body analysis used in this research. Advice and assistance of Dr. B. Fries, Dr. T. Khatua, and Dr. L. Cheng is gratefully acknowledged. Mr. Khanh Bui of LSTC is acknowledged for his assistance with the LS-DYNA3D and LS-TAURUS software.

## **References**

- Cheng, L., Werner, S., Khatua, T., Ray, R., and Lau, E., 1996a, "Heavy Truck Crashworthiness – Case Studies of Heavy Truck Accidents Involving Truck Occupant Fatality," *15th International Technical Conference on the Enhanced Safety of Vehicles*, Melbourne, Australia.
- Cheng, L., Werner, S., Girvan, D., and Khatua, T., 1996b, "Heavy Truck Crashworthiness – Collision Accidents," *15th International Technical Conference on the Enhanced Safety of Vehicles*, Melbourne, Australia.
- Cheng, L., Girvan, D., Werner, S., and Khatua, T., 1996c, "Heavy Truck Crashworthiness – 90° Rollover Accidents," *15th International Technical Conference on the Enhanced Safety of Vehicles*, Melbourne, Australia.
- Hallquist, J., Stillman, D., Lin, T.-S., 1994, "LS-DYNA3D User's Manual", Livermore Software Technology Corporation, Livermore, CA.
- Hallquist, John O. 1989, "DYNA3D—An Explicit Finite Element Program for Impact Calculations", *Crashworthiness and Occupant Protection in Transportation Systems*, ASME, AMD-Vol. 106, BED-Vol. 13. pp. 1–7.
- National Transportation Safety Board Accident Report, (1988), NTSB File No. 082.
- Parnell, T. Kim, White, Christopher V., Day, Shari E., Khatua, Tara, and Cheng, Louie, 1996, "Heavy Truck 180° Dynamic Rollover and Static Roof Crush Simulation", Phase II Report—SAE Heavy Truck Crashworthiness, SAE International, Warrendale, PA.
- Schwer, Leonard E. and Whirley, Robert G. 1996, "Lessons Learned in Modeling a Moving Deformable Barrier (MDB) Impacting a Rigid Wall", *International Journal of Crashworthiness*, Vol.1, No. 1.